

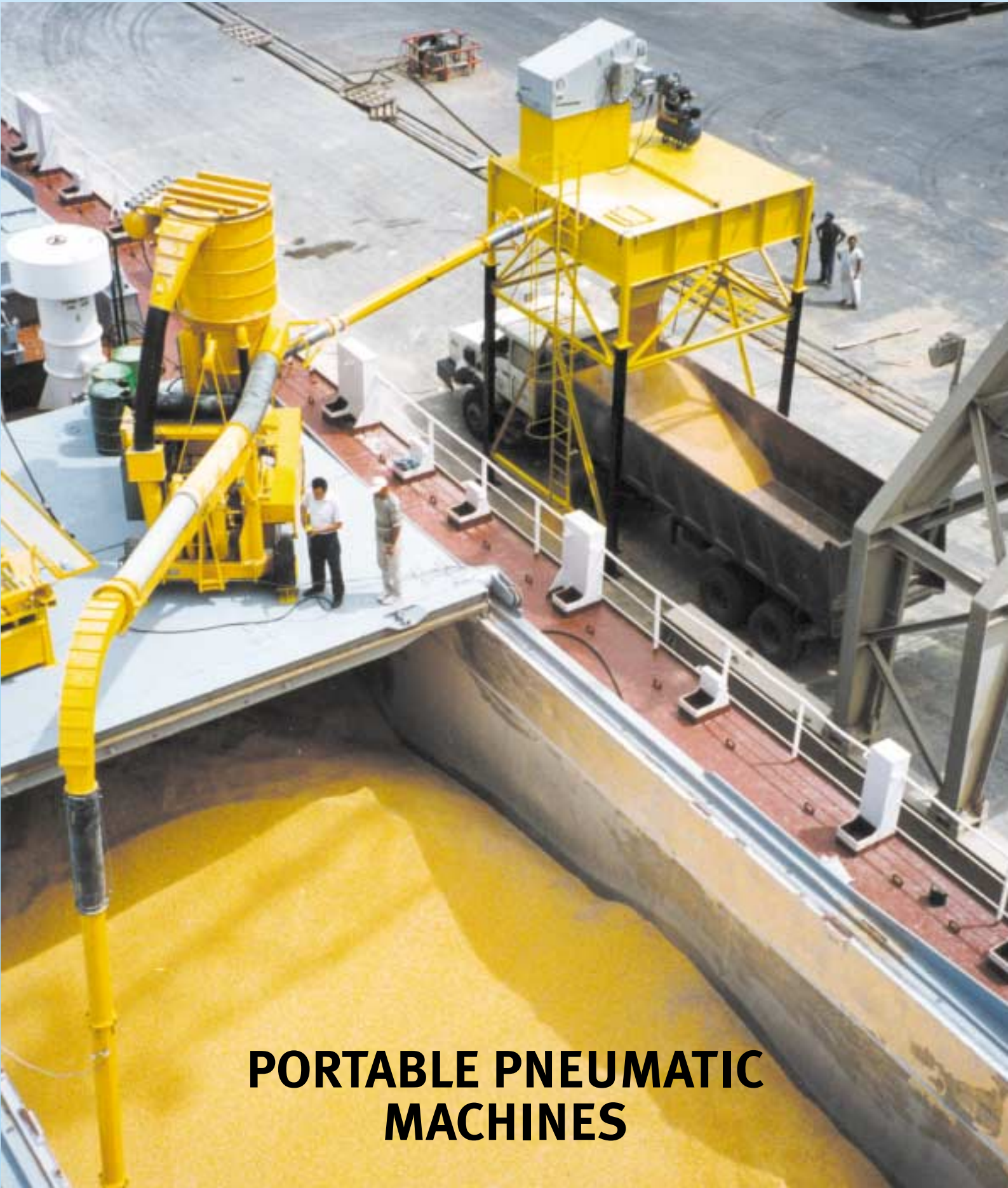

**Ships and Barges
Loading / Unloading
Ports and Silos Equipments**



**PORTABLE PNEUMATIC
MACHINES**



Type 60 - 80 - 100 - 120 and 200

Bulk handling of any kind of cereals, seeds, nuts, animal feeds and many other free-flowing materials.

Suction and/or Blowing

Special design for all climatic conditions: high salinity, dusty atmosphere and extreme temperatures. All parts treated by sand blasting: various antirust coatings and epoxy enamels.

Capacities: up to 250 metric tons per hour.

Weight: 3.5 - 8.5 tons according to type and accessories.

VIGAN high pressure 2 to 4 stages centrifugal turbo-blower with automatic air regulator for maximum reliability in all working conditions.

Diesel Engine – Electric motor: first class manufacturers with worldwide after-sales service. Up to 300 HP installed power and about 80 % of real power consumption for optimum energy savings and low fuel requirements: from 15 to 35 litres/hour.

VIGAN cast iron heavy duty airlock of 75 to 200 litres per rotation with replaceable and adjustable blade cutting tips and bronze sealing rings. Low speed and automatic airlock safety clutch.

Heavy duty main frame: rectangular section steel beams mounted on low pressure tyres. Two front wheels steered by articulated towing bars.

Transmission by V-belts and stainless pulleys, with double telescopic universal joints.

VIGAN assembly includes a full range of engine components such as extra large radiator and micronic air filtration system for maximum life time, minimum maintenance and trouble free operations.

Special safety and control devices such as measure instruments and automatic shutdowns.

Full range of accessories: front and rear hydraulic booms, automatic self-cleaning filter, special suction nozzles,...

For more information contact VIGAN

60 pages catalogue full of
technical data and coloured pictures





NEW MODEL

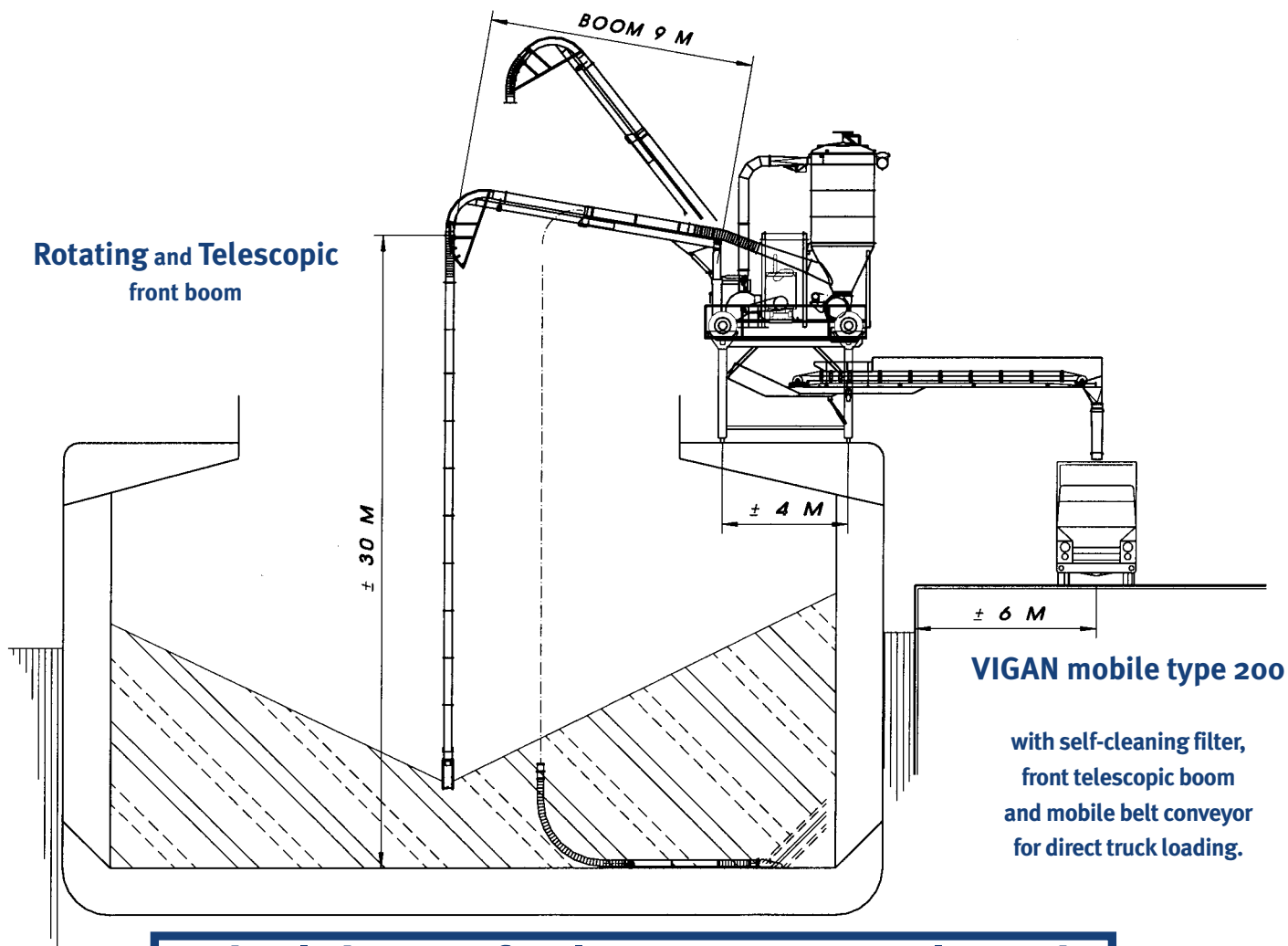

Ideal design for large size vessels and maximum daily unloading rate



**Rotating and Telescopic
front boom**

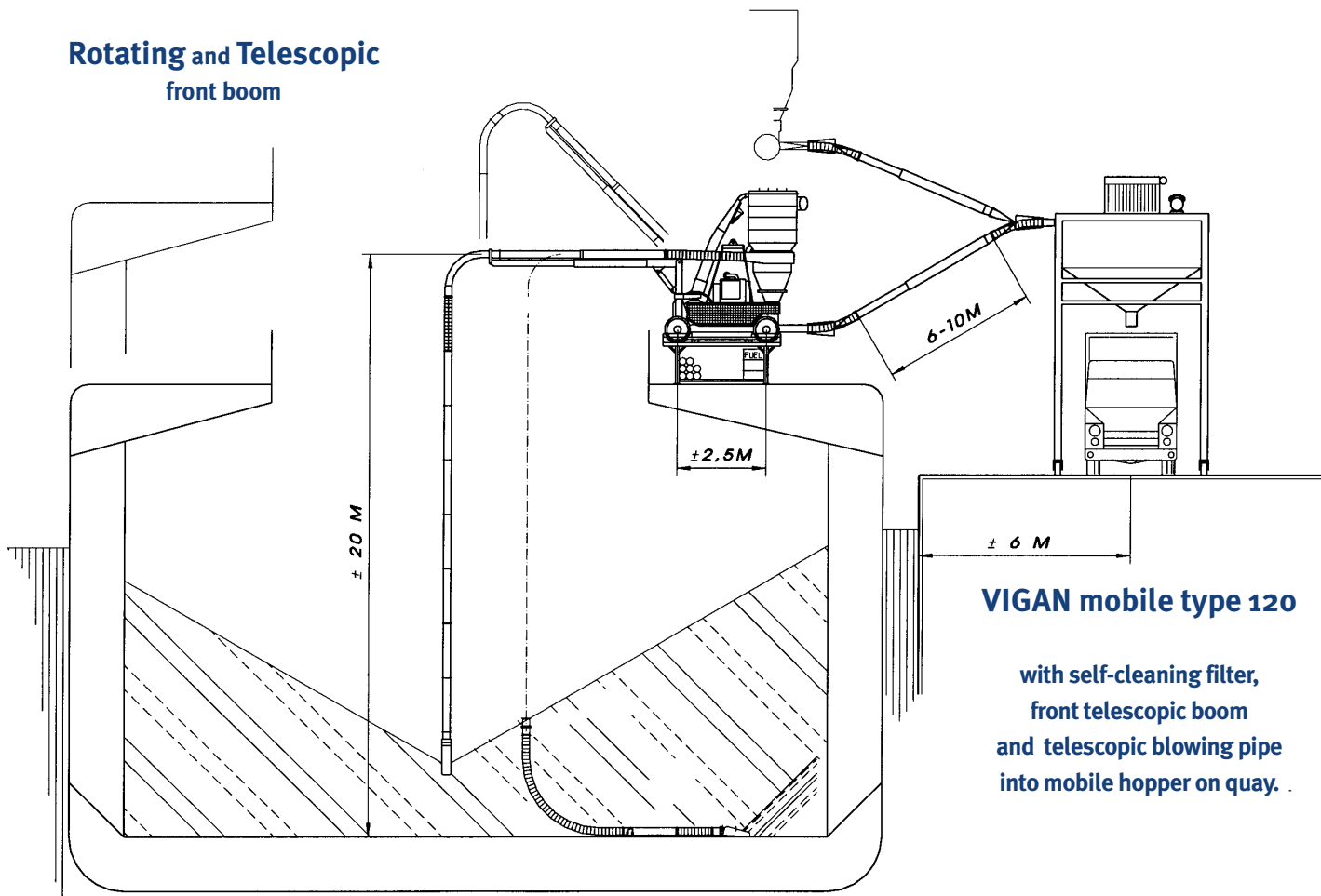

Hundreds of worldwide references



VIGAN: your partner in Bulk Handling

VIGAN TOWERS

Specially suited for barges or coaster vessels

Capacities: up to 400 metric tons per hour.

High efficiency: vertical and horizontal telescopic pipes, rotating boom (up to 17 metres) and filter-airlock assembly, multi stages VIGAN turbo blower.



VIGAN NIV SHIP UNLOADERS

Self-propelled gantries for any vessel size up to post Panamax

Capacities: up to 600 metric tons per hour (up to 1,200 metric tons/hour with 2 suction pipes).

Various designs:

- on rails, on rubber wheels or stationary;
- Diesel engine or electrical motor;
- boom length up to 30 metres;
- loading trucks, wagons, wharf conveyor, ...

Special options:

- winch for bulldozer or front loader;
- cutting suction nozzle for not free flowing products like soy bean meal, ...
- noise reduction (acoustic insulation) and many others.

50 pages fully detailed catalogue
with worldwide references

VIGAN SHIP LOADERS

All types of product and vessel sizes

Capacities: adapted to customers requirements.

Fully customized with many options such as stationary or self-propelled gantries, rotating and/or telescopic boom, telescopic loading spout, dust reduction, control cabin, ...



VIGAN Engineering s.a. Rue de L'Industrie, 16 - 1400 Nivelles (Belgium)

Phone: +32 67 89 50 41 - Fax: +32 67 89 50 60 - Internet: www.vigan.com - E-mail: info@vigan.com