

VIGAN

PORT EQUIPMENT - SHIP LOADERS / UNLOADERS

From initial project design to complete turnkey installations
with mechanical and/or pneumatic most reliable and profitable solutions



MOBILE & PORTABLE PNEUMATIC MACHINES

Vacuvators / Grain pumps



170 tons/hour

Dubai - U.A.E.



170 tons/hour

Latakia - Syria



140 tons/hour

Shangai - China



170 tons/hour

Baku - Azerbaijan

TYPE 100 - 120 & 200

Bulk handling of any kind of cereals, seeds, nuts, animal feeds and many other free-flowing materials.

Suction and/or Blowing

Special design for all climatic conditions: high salinity, dusty atmosphere and extreme temperatures. All parts treated by sand blasting: various antirust coatings and epoxy enamels.

Capacities: up to 250 metric tons per hour.

Weight: 3.5 - 8.5 tons according to type and accessories.

VIGAN high pressure 2 to 4 stages centrifugal turbo-blower with automatic air regulator for maximum reliability in all working conditions.

Diesel Engine – Electric motor: first class manufacturers with worldwide after-sales service.

Up to 300 HP installed power and about 80 % of real power consumption for optimum energy savings and low fuel requirements: from 15 to 35 litres/hour.

VIGAN cast iron heavy duty airlock of 75 to 200 litres per rotation with replaceable and adjustable blade cutting tips and bronze sealing rings.

Low speed and automatic airlock safety clutch.

Heavy duty main frame: rectangular section steel beams mounted on low pressure tyres. Two front wheels steered by articulated towing bars.

Transmission by V-belts and stainless pulleys, with double telescopic universal joints.

VIGAN assembly includes a full range of engine components such as extra large radiator and micron air filtration system for maximum life time, minimum maintenance and trouble free operations.

Special safety and control devices such as measure instruments and automatic shutdowns.

Full range of accessories: front and rear hydraulic booms, automatic self-cleaning filter, special suction nozzles,...

FOR MORE INFORMATION CONTACT
WWW.VIGAN.COM

60 pages catalogues full of technical data
and coloured pictures

HUNDREDS OF WORLDWIDE REFERENCES



170 tons/hour

Sfax - Tunisia

VIGAN MOBILE TYPE 120 :

with self-cleaning filter, front telescopic boom and telescopic blowing pipe into mobile hopper on quay

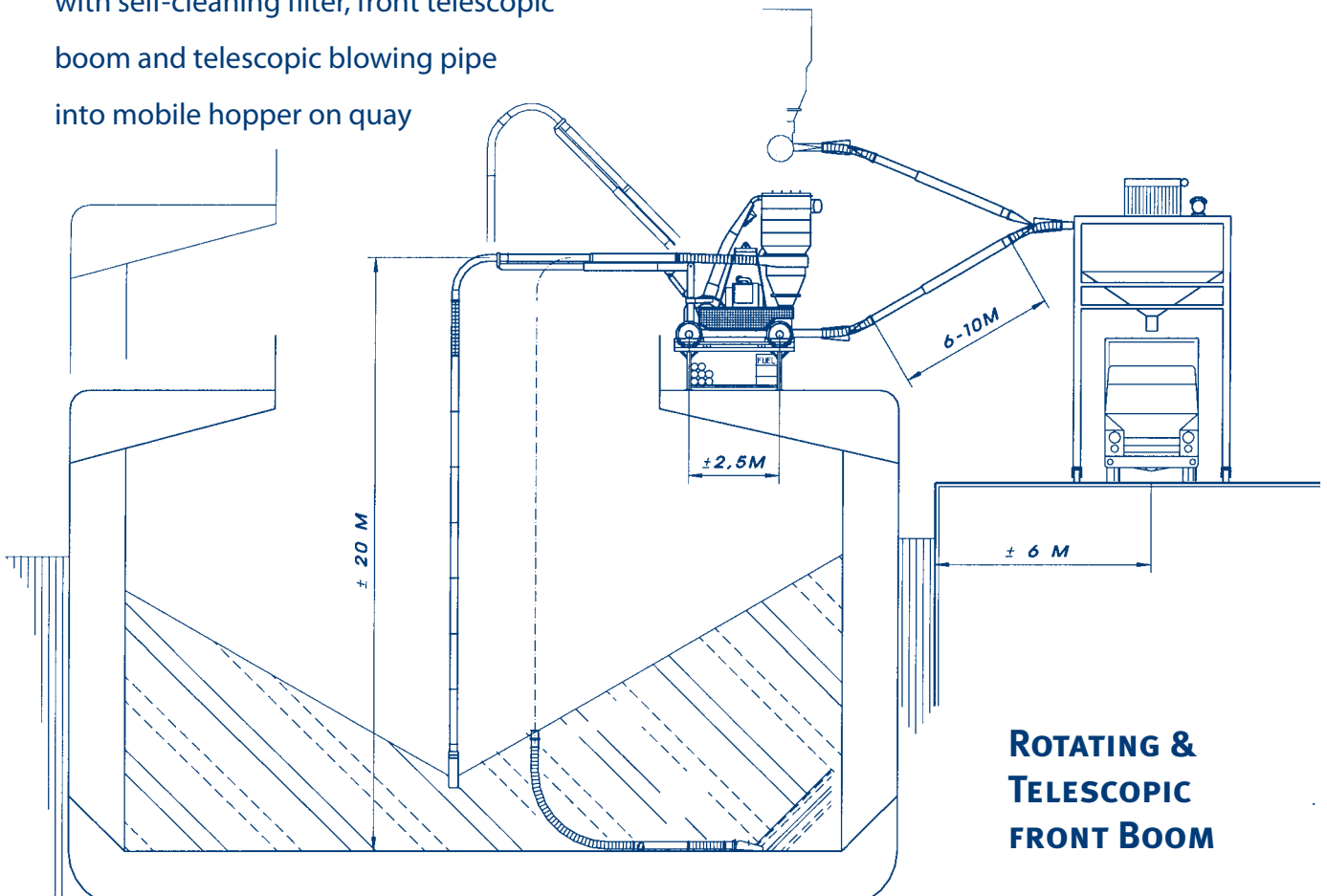

RELIABILITY AND COMPETITIVE PRICES

MOST VARIOUS APPLICATIONS

19 DISCHARGE CYCLONE

All welded construction.



See also nr. 32S.



250 tons/hour
Dekheila- Egypt

Operation: To
Useful to pre
of delicate p
trucks, elev
conveyors,
Left hand

dia. 700
height



140 tons/hour
Aqaba - Jordan

20

A wide range of accessories as described in Vigan's catalogue, allows fulfilling almost any customer's requirements, such as:

- from ship to trucks, railway cars or quay conveyors
- for transshipment from big vessels to barges, and vice-versa
- for loading vessels, wagons, trucks, ...
- for emptying or filling silos: from/to train, truck, or conveyors and many other alternatives

clone 32s CD with bended inlet

Thickness
5 mm
5 mm



Purpose: To correctly mix and metre the air and products being sucked in, with the possibility of working with the positive pressure whilst observing the safety rules 1 and 2 when working in confined spaces.
Operation:

Dia.
205 mm
225 mm



170 tons/hour
Lehaucourt - France

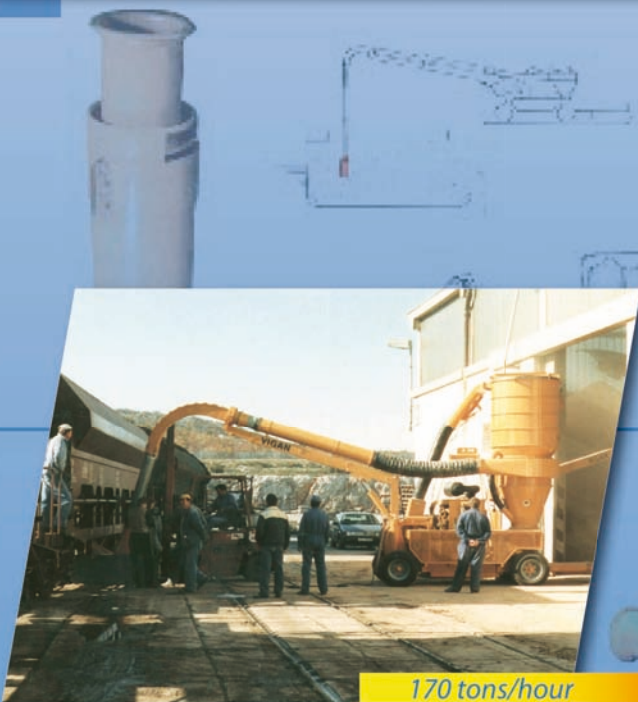

170 tons/hour
Rijeka - Croatia

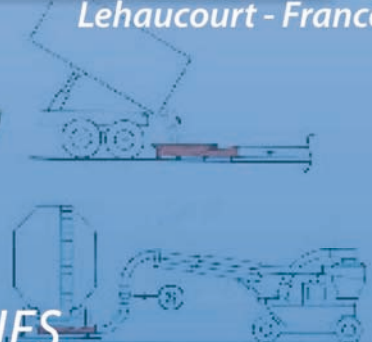

**COMPLETE RANGE OF ACCESSORIES
FOR WIDE VARIETY OF WORKING CONDITIONS**



250 tons/hour
Alexandria - Egypt

VIGAN MOBILE TYPE 200 :

with self-cleaning filter,
front telescopic boom
and mobile belt conveyor
for direct truck loading

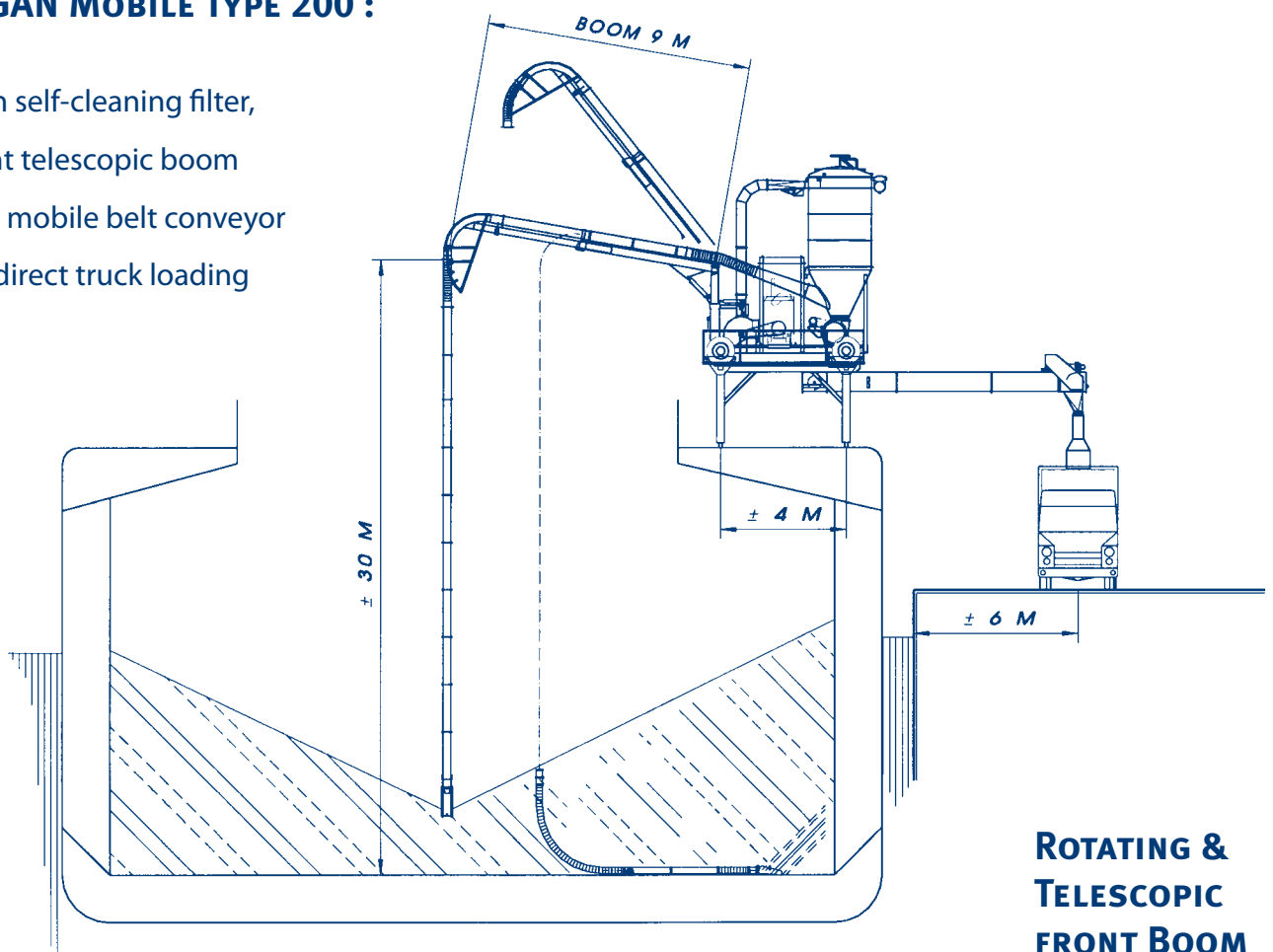

MORE THAN 1200 VIGAN MACHINES SOLD WORLDWIDE



ENGINEERING S.A.

Rue de l'Industrie, 16 • 1400 Nivelles • Belgium
Phone: +32 67 89 50 41 • Fax: +32 67 89 50 60
www.vigan.com • info@vigan.com

MANUFACTURES BULK MATERIALS HANDLING SOLUTIONS MAINLY:

- ◆ Mobile pneumatic conveyors or vacuators or grain pumps
- ◆ Pneumatic continuous barge unloaders and mechanical barge loaders
- ◆ Mechanical and pneumatic continuous ship unloaders for vessels up to post-Panamax
- ◆ Mechanical loaders for any size of ships

Vigan capabilities include also complete turnkey projects for port terminal including ship unloading & loading, storage facilities and bagging operations.

